

DIONE F1 EXPLODED VIEW

CONTROL PANEL PARTS

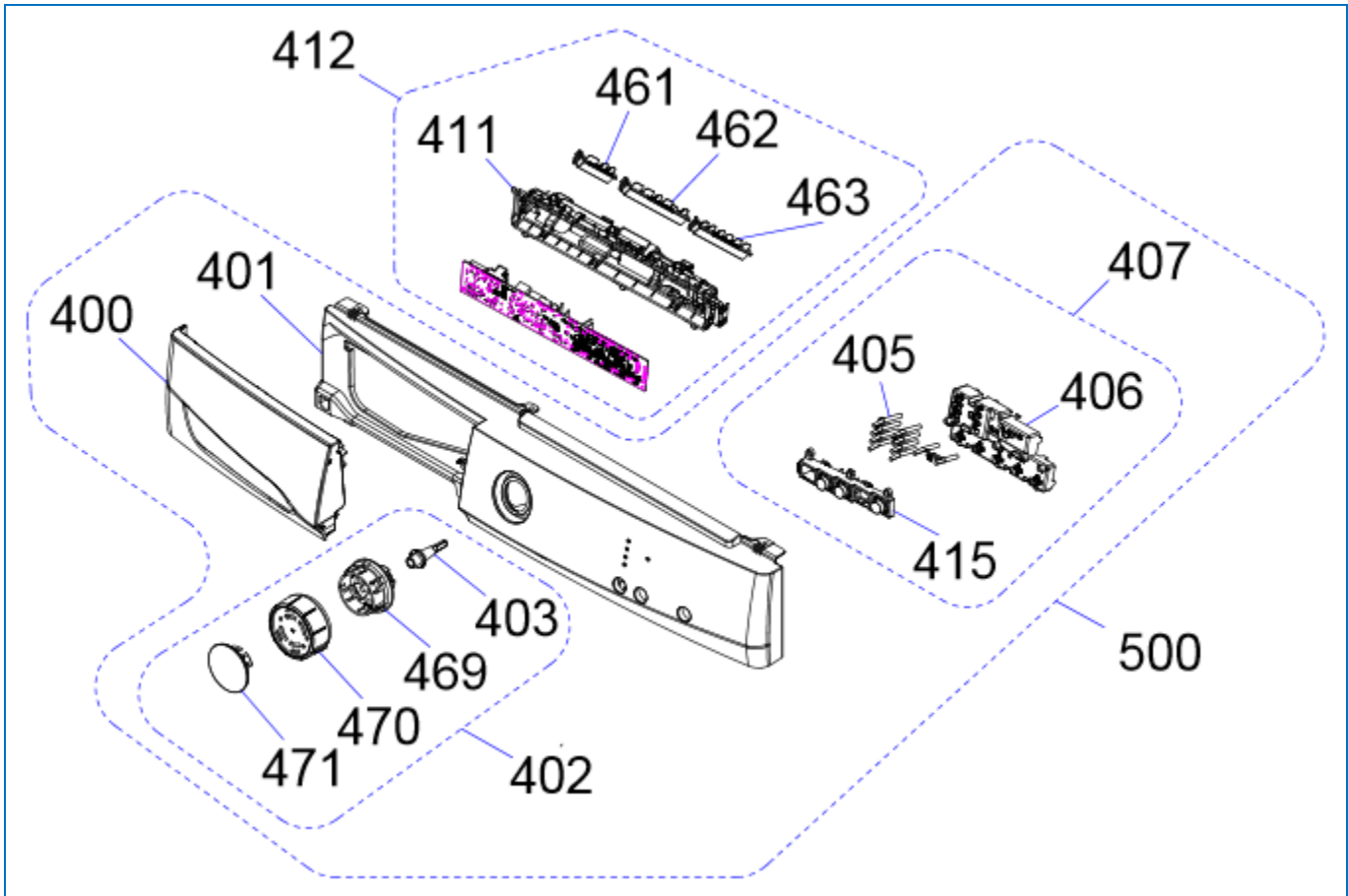

NO	PART NAME	QUANTITY
400	DETERGENT DRAWER COVER	1
401	CONTROL PANEL	1
402	PR. ADJUSTMENT KNOB GR	1
403	PROGRAM ADJUSTMENT SHAFT	1
405	LIGHT GUIDE	1
406	CARD BOX	1
407	BUTTON-LIGHT GUIDE GROUP	1
411	PCB BOX	1
412	ELECTRONIC CARD GROUP	1
415	SELECTION BUTTONS	1
461	PCB SOCKET HOLDER PLASTIC F1	1
462	PCB SOCKET HOLDER PLASTIC F2	1
463	PCB SOCKET HOLDER PLASTIC F3	1
469	PROGRAM ADJ. INSERT	1
470	PROGRAM ADJ. KNOB	1
**471	**PROGRAM ADJ. KNOB COVER	1
500	CONTROL PANEL GROUP	1

** This spare part is optional and depends on agreed specifications. Therefore you may not find this part in product's spare part list.

DIONE F1 EXPLODED VIEW

FRONT PANEL PARTS

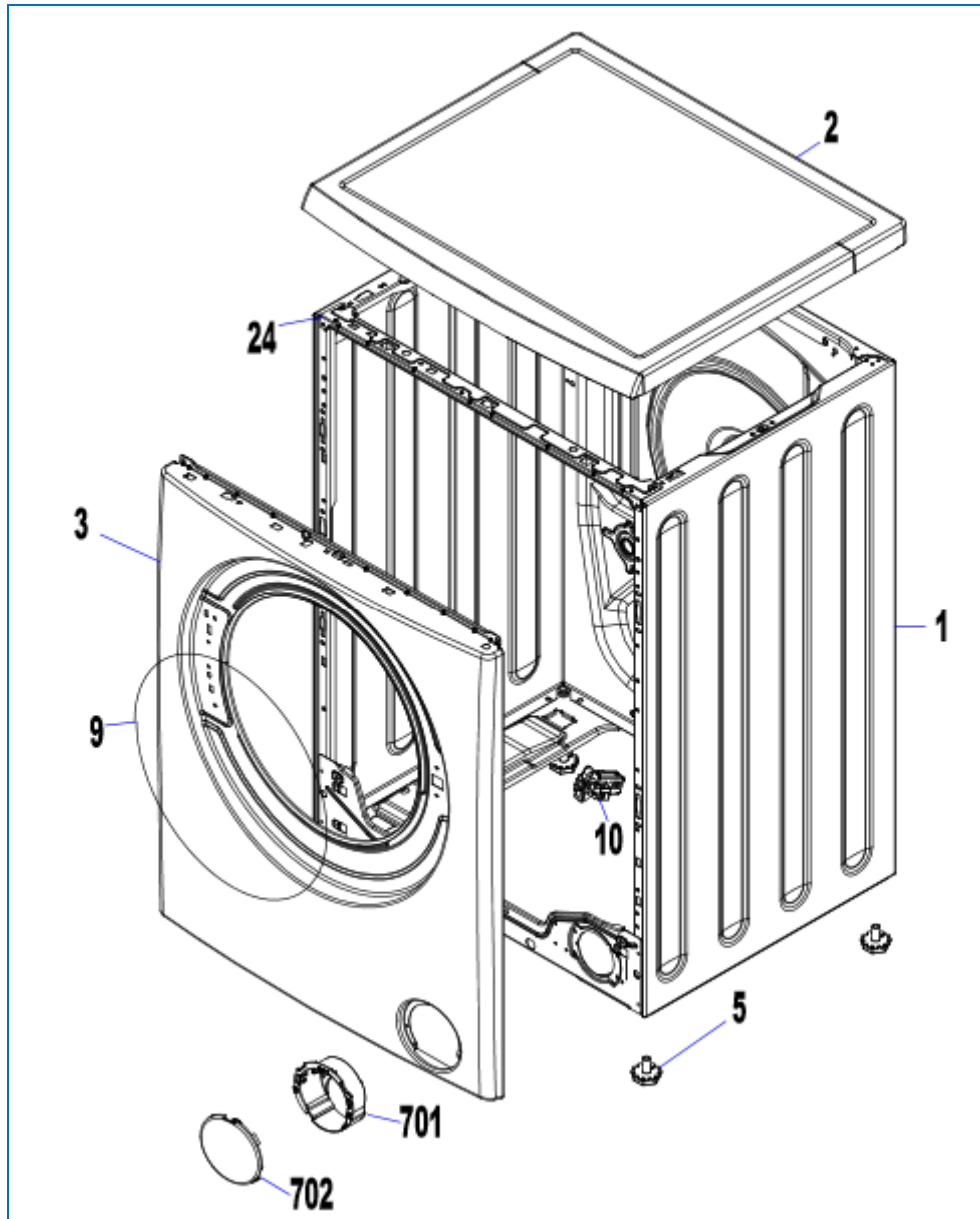

NO	PART NAME	QUANTITY
1	BODY GROUP PAINTED	1
2	UPPER TRAY GROUP	1
3	FRONT PANEL GROUP	1
5	ADJUSTABLE FEET GROUP	4
9	BODY-GASKET CLAMP	1
10	DOOR LOCK	1
701	PUMP COVER HOUSING	1
702	PUMP COVER	1

WASHING GROUP PARTS

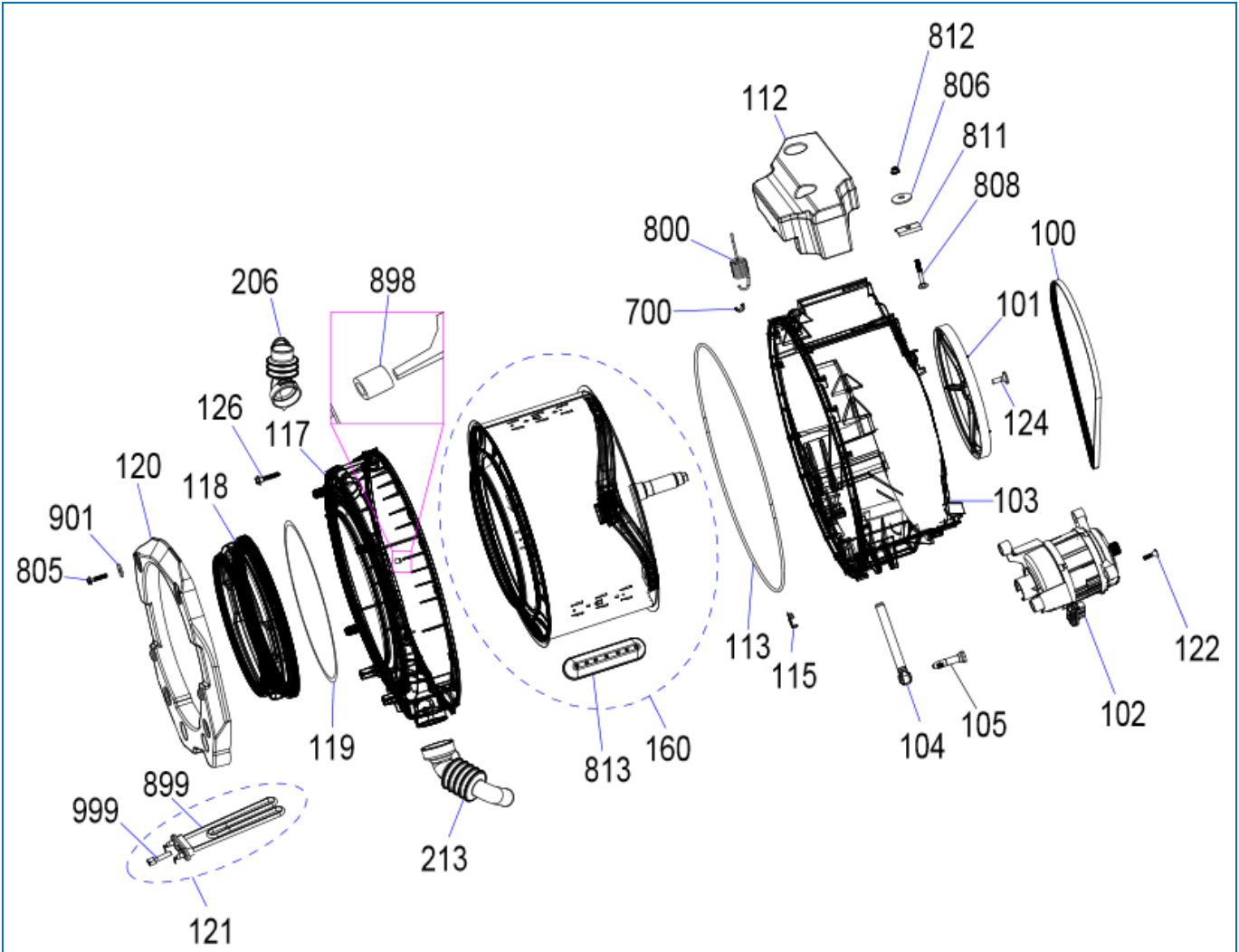

DIONE F1 EXPLODED VIEW

NO	PART NAME	QUANTITY
100	BELT	1
101	DRIVEN PULLEY	1
102	MOTOR	1
103	REAR TUB GROUP	1
104	SHOCK ABSORBER	2
105	SHOCK ABSORBER PIN	2
112	UPPER COUNTERWEIGHT	1
113	TUB SEAL	1
115	RESISTANCE FIXING WIRE (INSIDE TUB)	1
117	FRONT TUB	1
118	TUB BELLOWS SEAL	1
119	TUB-GASKET CLAMP	1
120	FRONT CONCRETE WEIGHT	1
121	RESISTANCE GROUP	1
122	SCREW FIXING MOTOR-TUB (COUNTERSUNK HEAD BOLT TORX)	4
124	BOLT FIXING PULLEY-DRUM SHAFT (COUNTERSUNK HEAD BOLT M8X29)	1
126	SCREW FIXING FRONT TUB-REAR TUB (HEXAGON HEAD BOLT PT TYPE 2)	4
160	DRUM GROUP	1
206	TUB ENTERANCE WITH BELLOW HOSE	1
213	TUB EXIT WITH BELLOW HOSE	1
700	TUB SPRING PLASTIC (TUB SIDE-TUB HANGER SPRING PART-2)	2
800	TUB SPRING	2
805	SCREW FIXING FRONT COUNTERWEIGHT-FRONT TUB (HEXAGON HEAD BOLT RAKB)	4
806	WASHER BETWEEN UPPERCOUNTERWEIGHT AND NUT (PLAIN WASHER)	2
808	BOLT FIXING UPPER COUNTERWIGHT-REAR TUB (MUSHROOM HEAD SQUARE NECK BOLT)	2
811	UPPER CONCRETE SUPPORT BRACKET	2
812	NUT FIXING UPPER COUNTERWEIGHT-REAR TUB (HEX.NUT WITH FLANGE SERRATED)	2
813	PLASTIC LIFTER	3
**898	**PSW HOSE MOUNTING RUBBER	2
899	RESISTANCE WITHOUT NTC	1
901	WASHER BETWEEN FRONT COUNTERWEIGHT AND SCREW FIXING IT (PLAIN WASHER)	4
999	NTC	1

** This spare part depends on front tub type. Some products does not have this spare part due to their front tub design.

DIONE F1 EXPLODED VIEW

DETERGENT DRAWER GROUP

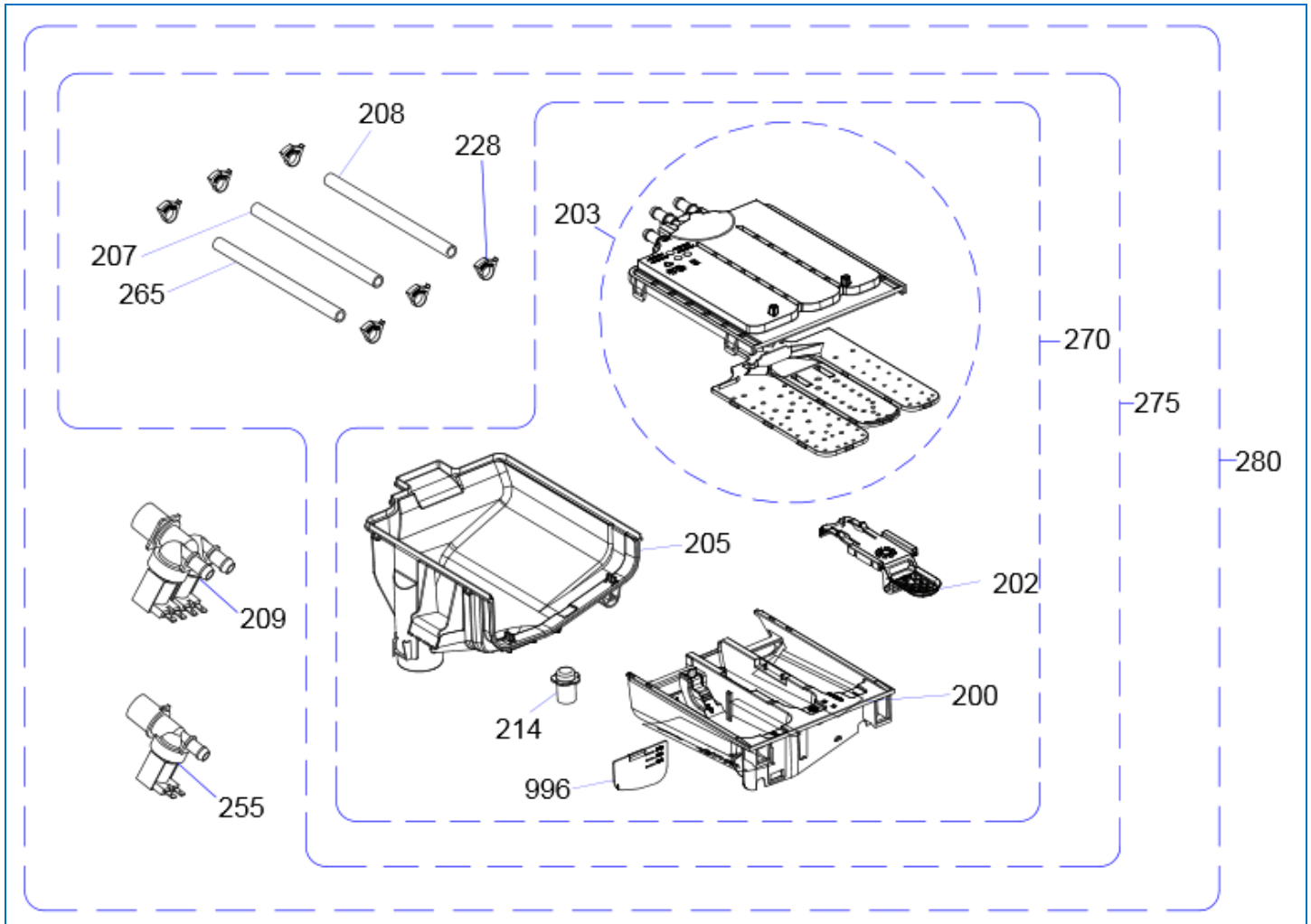

NO	PART NAME	QUANTITY
200	DETERGENT DRAWER	1
202	SIPHON COVER	1
203	WATER DISTRIBUTION PLATE GROUP	1
205	DETERGENT DRAWER HOUSING	1
207	VALVE-DETERGENT BOX HOSE	1
208	VALVE-DETERGENT BOX HOSE	1
**265	**VALVE-DETERGENT BOX HOSE	1
209	VALVE(TWO EXIT)	1
**255	**VALVE(ONE EXIT)	1
214	DETERGENT DRAWER LOCKING PART	1
228	PLASTIC HOSE CLAMP	6
996	LIQUID DETERGENT LEVEL PLATE	1
270	DETERGENT BOX GROUP (WITHOUT HOSES & CLAMP(S))	-
275	DETERGENT BOX GROUP (WITH HOSES & CLAMP(S), WITHOUT VALVE(S))	-
280	DETERGENT BOX GROUP (FULL)	-

** Those spare parts are only available for models with hot water inlet.

PRESSURE SWITCH HOSE GROUP

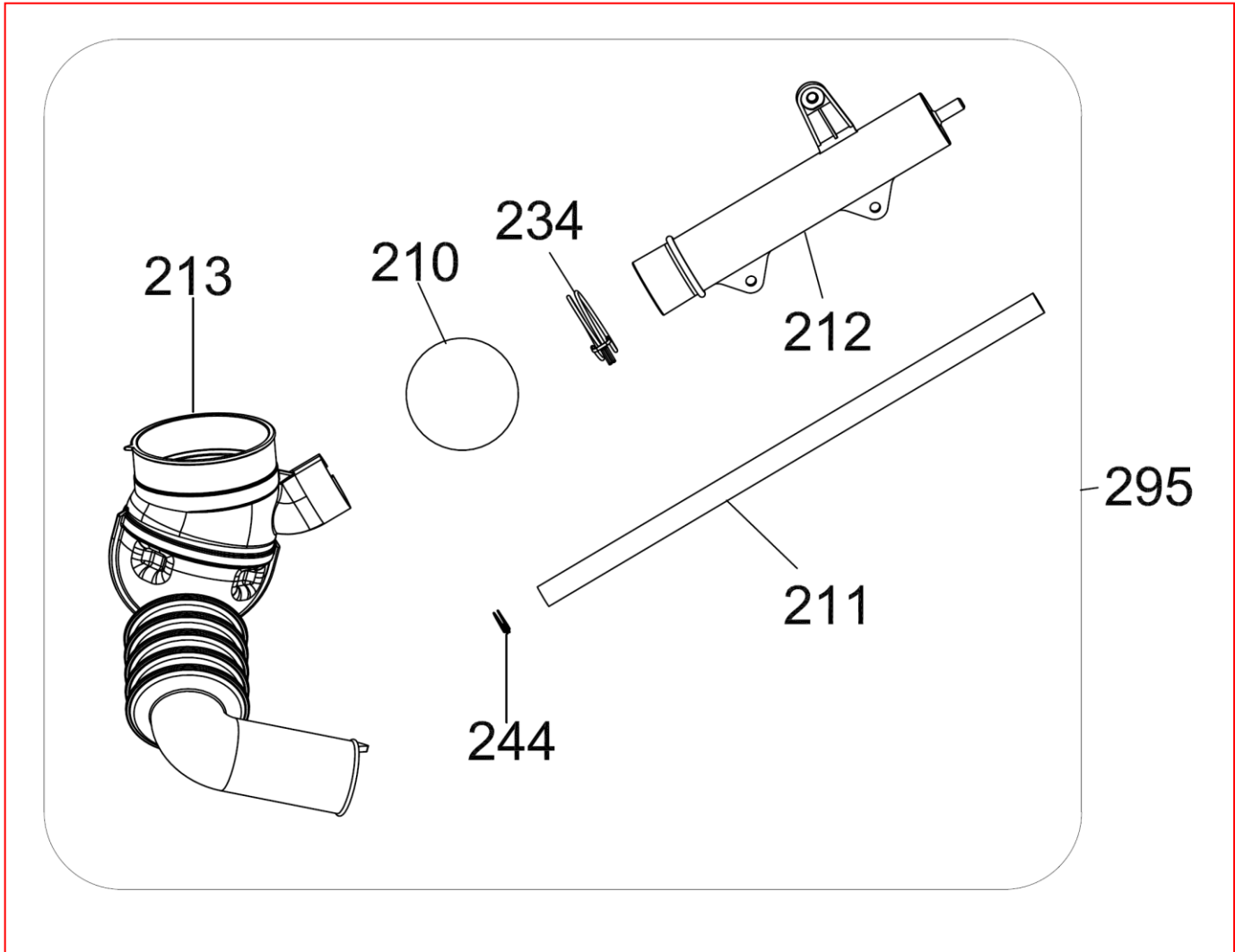

NO	PART NAME	QUANTITY
210	TUB EXIT BELLOW HOSE BALL	1
213	TUB EXIT WITH BELLOW HOSE	1
212	PRESSURE SWITCH WATER RESERVOIR	1
211	PRESSURE SWITCH HOSE	1
234	HOSE CLAMP Ø32,7	1
244	HOSE CLAMP Ø9,6	1
295	PRESSURE SWITCH HOSE GROUP	1

213-212-211-234-244----- PRESSURE SWITCH HOSE GROUP

DIONE F1 EXPLODED VIEW

BODY GROUP PARTS

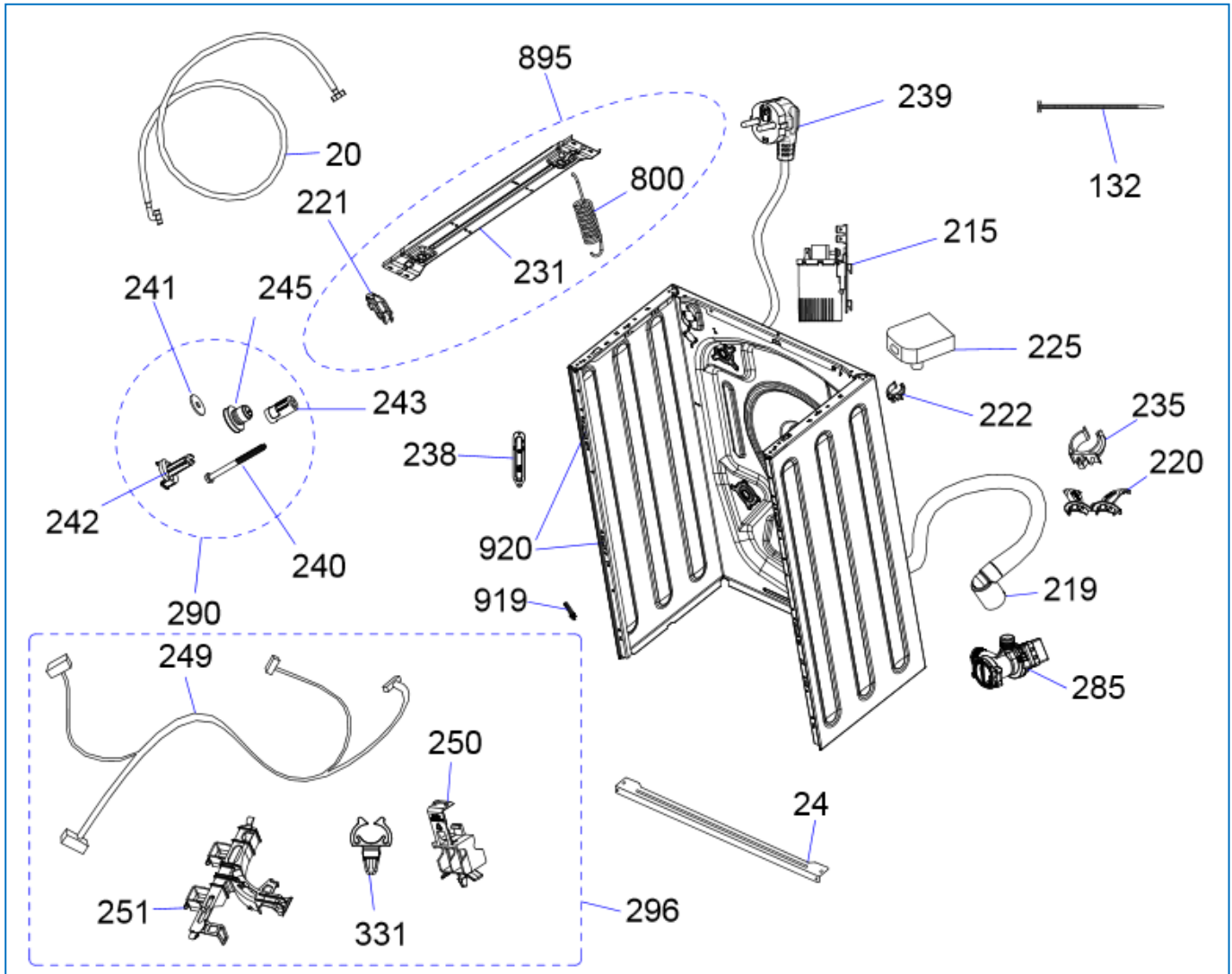

DIONE F1 EXPLODED VIEW

NO	PART NAME	QUANTITY
20	WATER INLET HOSE	1
24	FRONT SUPPORT BRACKET	1
132	CABLE TIE	-
285	PUMP GROUP	1
220	DRAIN HOSE ROUTER PLASTIC	1
219	DRAIN HOSE	1
225	PRESSURE SWITCH	1
215	EMI FILTER	1
296	CABLE GROUP	1
249	CABLE HARNESS	1
250	CABLE HARNESS HOLDER PLASTIC	1
251	CABLE HOLDER & ROUTER	1
331	CABLE HOLDER WITH PEG (LOCKING WIRE SADDLE)	1
895	SPRING HANGER GROUP	1
800	HANGER SPRING	2
221	HANGER SPRING HOUSING PLS.	2
231	SPRING HANGER BRACKET	1
235	DRAIN HOSE HOLDING PLS	2
239	POWER CORD GROUP	1
222	PRESSURE SWITCH MOUNTING CLIP	1
238	SPEED CONTROL HOLE STOPPER	1
290	TRANSPORT SCREW GROUP	4
245	TRANSPORT SCREW EPDM	4
242	TRANSPORT SCREW PLASTIC A	4
243	TRANSPORT SCREW PLASTIC B	4
240	TRANSPORT SCREW	4
241	WASHER BETWEEN TRANSPORT SCREW PLASTIC A AND TRANSPORT SCREW (PLAIN WASHER)	4
919	HOSE CLAMP Ø8,6	
920	FRONT PANEL DROP FIXING PLASTIC	4

DOOR GROUP

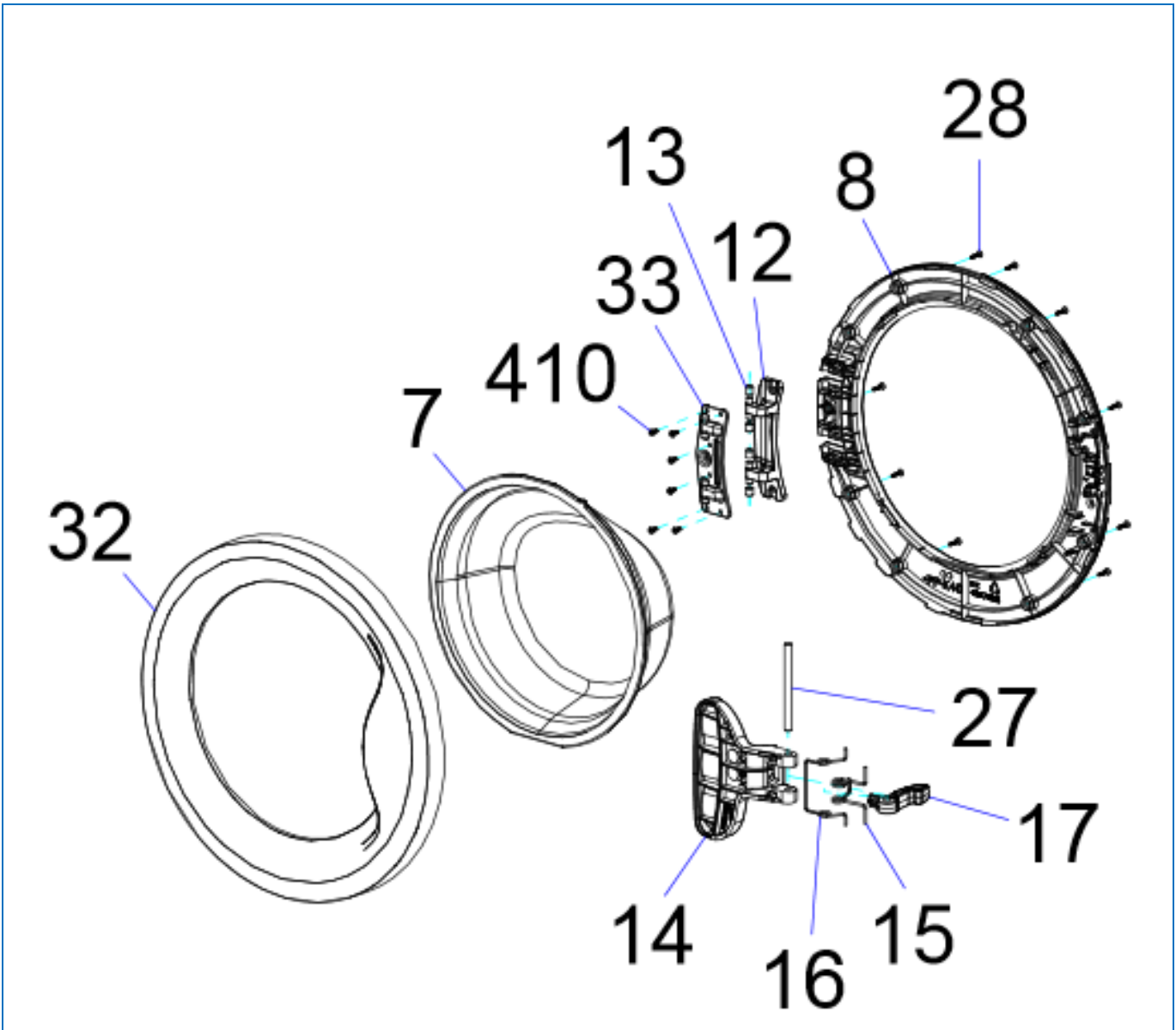

NO	PART NAME	QUANTITY
7	DOOR GLASS	1
8	INNER DOOR PLASTIC	1
12	HINGE	1
13	HINGE BUSH	4
14	DOOR HANDLE	1
15	HOOK SPRING	1
16	HANDLE SPRING	1
17	DOOR HOOK	1
27	HANDLE PIN	3
28	SCREW 3,5X16 PAN HEAD WITH COLLAR UNDER HEAD SERRATED	9
32	OUTER DOOR PLASTIC	1
33	DOOR HINGE SUPPORT SHEET	1
410	SCREW 4X12 PAN HEAD WITH COLLAR UNDER HEAD SERRATED	6
50	PORTHOLE GROUP (all parts above)	1

DIONE F1 EXPLODED VIEW

PACKAGING GROUP

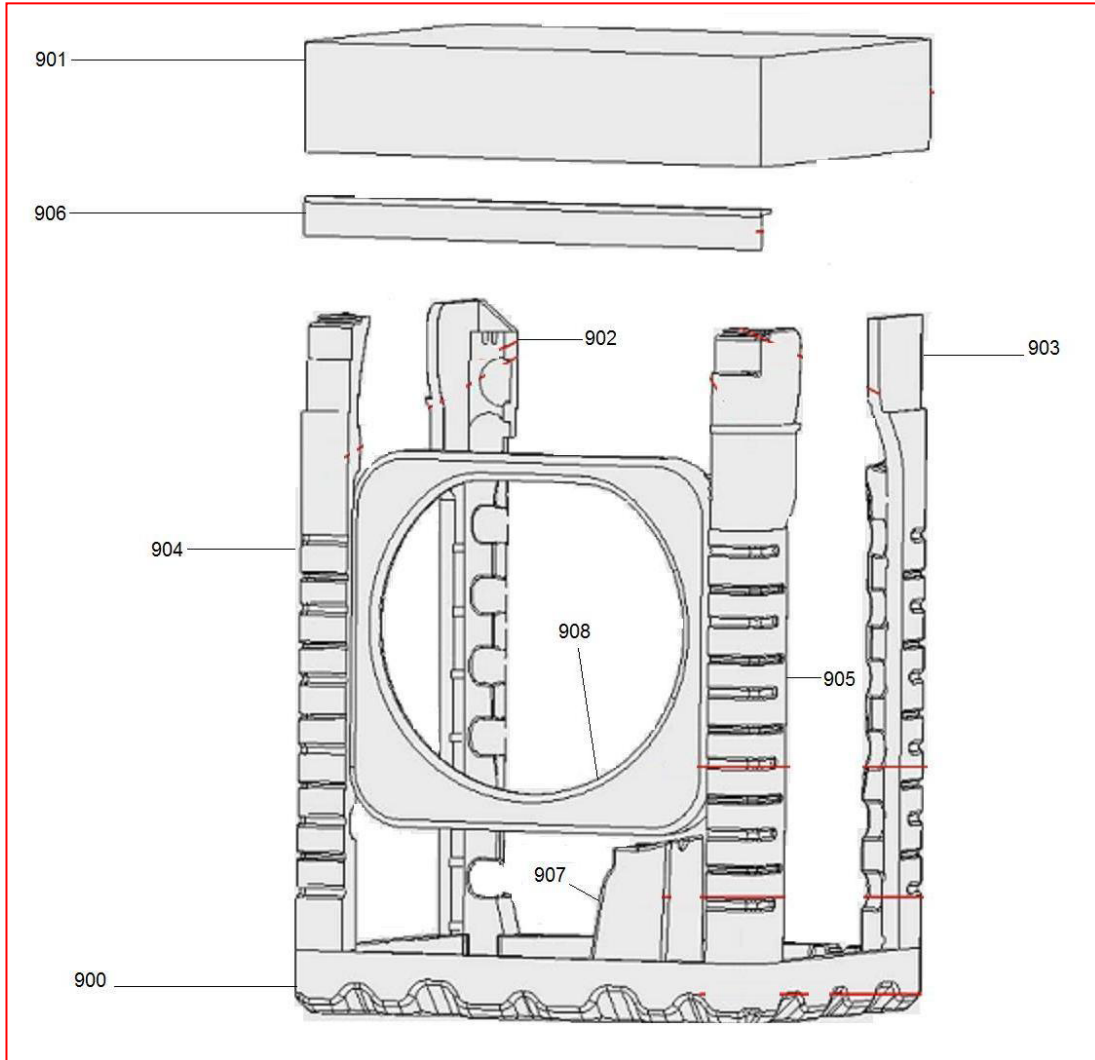

NO	PART NAME	QUANTITY
900	BOTTOM STYROFOAM	2
901	TOP CARTON	1
902	REAR STYROFOAM(LEFT)	1
903	REAR STYROFOAM(RIGHT)	1
904	FRONT STYROFOAM LEFT	1
905	FRONT STYROFOAM RIGHT	1
906	CORNER CARDBOARD	1
907	TUB SUPPORT STYROFOAM	1
908	PORTHOLE PRO. STYROFOAM	1

DIONE F1 EXPLODED VIEW

ACCESSORIES

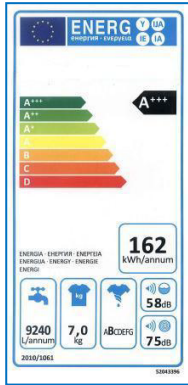

995



996



997



998

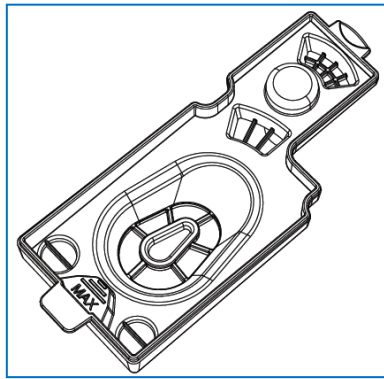

1901

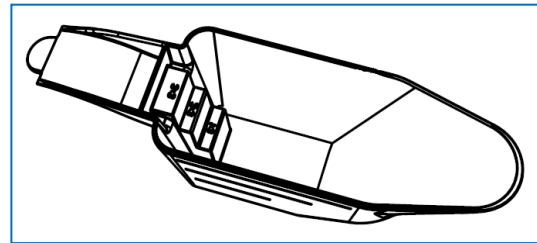

1900

NO	PART NAME	QUANTITY
995	ENERGY LABEL	1
996	LIQUID DETERGENT LEVEL PLATE	1
997	DRAIN HOSE COAT RACK	1
998	TRANSPORT SCREW STOPPER	4
*1900	*DETERGENT POWDER SCALE	*
*1901	*LIQUID DETERGENT RESERVOIR	*

* This is an optional accessory, the product may not have it by default depending on agreed specifications, and still it can be ordered as a spare part.